

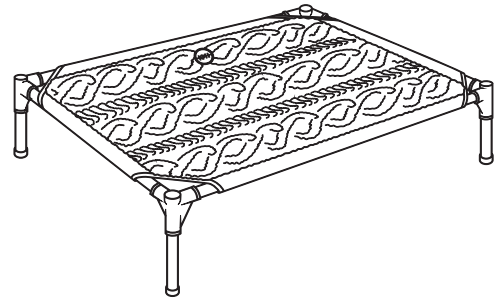

PET HAMMOCK

K&H PET PRODUCTS
CENTRAL GARDEN & PET
COLORADO SPRINGS, CO
www.khpet.com • 1-877-738-5188

K&H Pet Products with design
is a registered trademark of
K&H Manufacturing, LLC.
©2026 K&H Manufacturing, LLC.



ASSEMBLY INSTRUCTIONS:

BEFORE ASSEMBLY check that you
have received all of the parts needed:

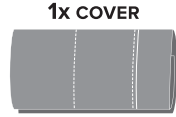

4x ONE DOT
FRAME PIECES

2x LONG
FRAME PIECES



4x CORNER
LEGS

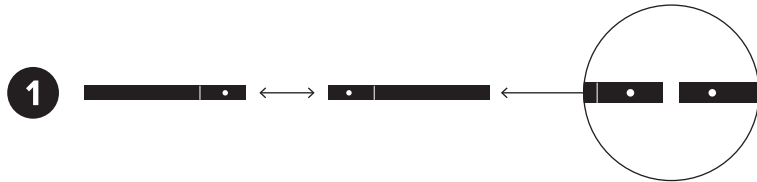

Connect each pair of **ONE DOT FRAME PIECES** together at the connection ends with the dots.

This should result in a total of 2 connected **SIDE** frame pieces.

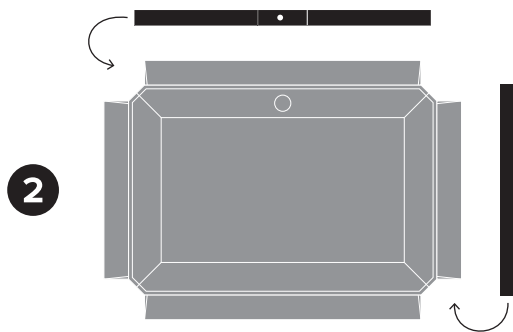

Spread the **COVER** right side down.

Slide each connected **FRAME PIECE** into the corresponding **FABRIC CHANNEL** of the **COVER**.

Connected **ONE DOT** pieces go in the channels on the **LONGER SIDES** of the cover. **LONG FRAME** pieces go in the channels on the **SHORTER ENDS** of the cover.

Repeat for each side of the cover so that every fabric channel has a connected **FRAME PIECE**.

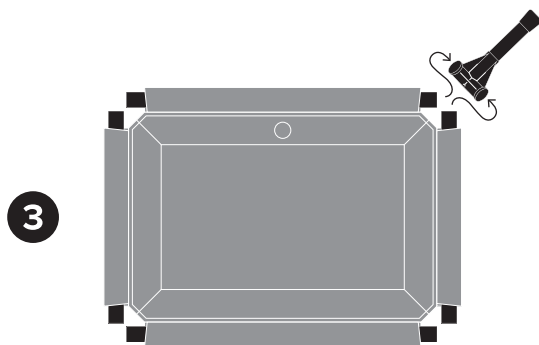

At the corners, connect the **FRAME PIECES** into the two holes of the **CORNER LEG PIECES** with the foot cap facing upwards.

Repeat for the remaining **CORNER LEGS** so that all **FRAME PIECE** ends are secured.

Turn the cot right side up and check that all connections are firmly secured.

REV1_01-01-26

CAUTION: Rubber feet are easily removable and have a washer inside. Therefore, pets and small children should be supervised near this product.

PLEASE NOTE: Wash **ONLY** the cover. Remove it the frame entirely before washing. Reassemble following the instructions included.

CARE INSTRUCTIONS:
Machine wash cold gentle cycle.
Line dry or tumble dry low.
Do not bleach.
Do not dry clean or iron.

K&H LIMITED ONE YEAR WARRANTY

Our warranty is as follows: K&H Pet Products warrants to the original consumer, that this product will be free of defects and workmanship for a period of one year from the date of purchase. The manufacturer's liability hereunder is limited to replacement of the product. This warranty is void if the product has been damaged by accident, unreasonable use, neglect, tampering, or other causes not arising from defects in material and workmanship.

To initiate a warranty claim during the warranty period, please follow the steps below:
Call our customer service team at **877-738-5188** or email us at questions@khmfg.com.
Please include the following details when contacting us:

- A clear description of the defect.
- Pictures of the defect (this will help us assess the issue more efficiently).
- Proof of purchase (receipt or order confirmation) to verify the product's eligibility for warranty coverage.

Upon receiving your claim, we will promptly review the information provided and notify you of the next steps in the replacement process.

We are committed to ensuring your satisfaction and will assist you in resolving any warranty concerns as quickly as possible.

THANKS!