

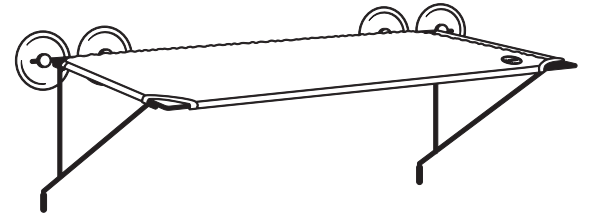

EZ MOUNT WINDOW PERCH

K&H PET PRODUCTS
CENTRAL GARDEN & PET
COLORADO SPRINGS, CO
www.khpet.com • 1-877-738-5188

K&H Pet Products with design
is a registered trademark of
K&H Manufacturing, LLC.
©2026 K&H Manufacturing, LLC.



BEFORE ASSEMBLY:

Check that you have received all of the parts needed:

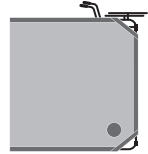

1x FRAME WITH COVER

2x EXTENSION RODS

4x SUCTION CUPS



ASSEMBLY INSTRUCTIONS:

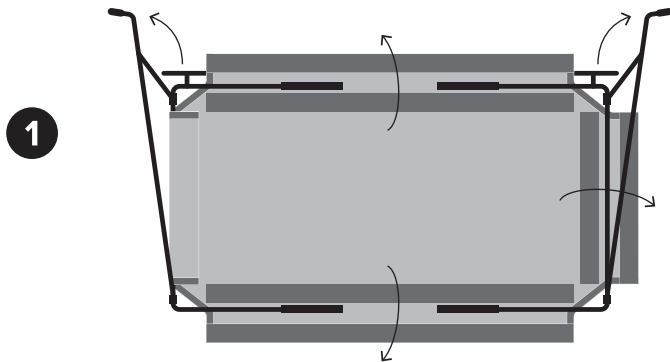

1

Lay the **FRAME WITH COVER** flat with the sleep surface facing down.

DETACH the hook and loop material on **BOTH LONG SIDES** and on **ONE** of the **SHORT SIDES**.

Move the **SIDE SUPPORT BRACES** into the upright position.

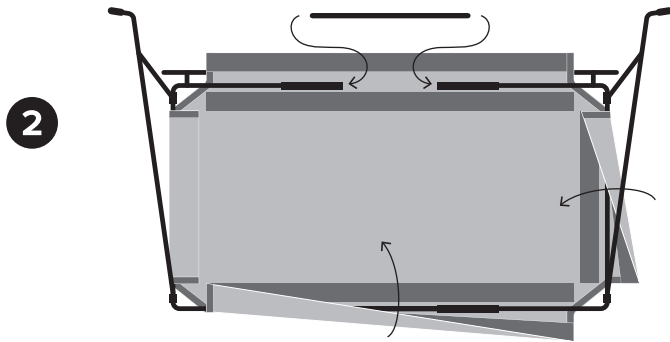

2

Install both the **EXTENSION RODS** into the joints on the **LONG SIDES**.

REATTACH the hook and loop material by folding all three sides back to the original secured position and pressing down for a firm hold.

Adjust the material around all edges of the frame until the cover is nice and tight on the frame.

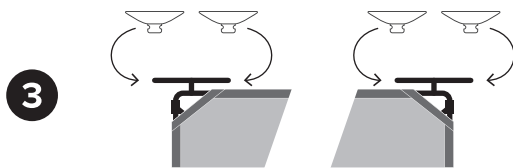

3

Turn the perch over with the sleep surface facing up and install the **SUCTION CUPS** onto the **T BARS** at the back of the frame (2 suction cups per side).

The **SUCTION CUPS** are meant to be tight and may require some turning and pushing for proper installation.

REV1_01-01-26

K&H LIMITED ONE YEAR WARRANTY

Our warranty is as follows: K&H Pet Products warrants to the original consumer, that this product will be free of defects and workmanship for a period of one year from the date of purchase. The manufacturer's liability hereunder is limited to replacement of the product. This warranty is void if the product has been damaged by accident, unreasonable use, neglect, tampering, or other causes not arising from defects in material and workmanship.

To initiate a warranty claim during the warranty period, please follow the steps below:
Call our customer service team at **877-738-5188** or email us at questions@khmfg.com.
Please include the following details when contacting us:

- A clear description of the defect.
- Pictures of the defect (this will help us assess the issue more efficiently).
- Proof of purchase (receipt or order confirmation) to verify the product's eligibility for warranty coverage.

Upon receiving your claim, we will promptly review the information provided and notify you of the next steps in the replacement process.

We are committed to ensuring your satisfaction and will assist you in resolving any warranty concerns as quickly as possible.

THANKS!



EZ MOUNT WINDOW PERCH

K&H PET PRODUCTS
CENTRAL GARDEN & PET
COLORADO SPRINGS, CO
www.khpet.com • 1-877-738-5188

K&H Pet Products with design
is a registered trademark of
K&H Manufacturing, LLC.
©2026 K&H Manufacturing, LLC.

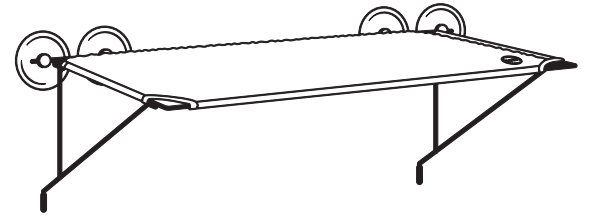

IMPORTANT: Thoroughly clean your **WINDOW** and **SUCTION CUPS** before you install the product for maximum hold!

INSTALLATION INSTRUCTIONS:

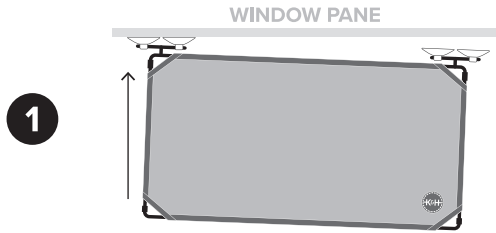

Holding the Window Perch with the **SUCTION CUPS** facing the window, gently push one side of **SUCTION CUPS** into the **WINDOW PANE**.

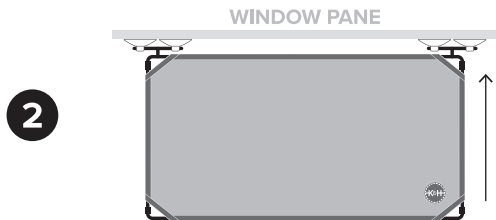

Level the Window Perch and then gently push the second side of **SUCTION CUPS** into the **WINDOW PANE**.

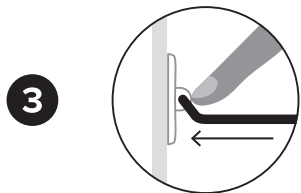

Using your fingers, push the remaining air out of all **SUCTION CUPS** to ensure a proper adhesion.

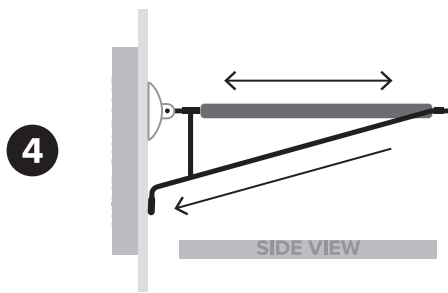

Extend each of the **SIDE SUPPORT BRACES** straight down and allow the frame to naturally rest with the **RUBBER TIPS** against the window pane.

Make sure the Window Perch is level. Readjust as needed.

PLEASE NOTE:

Wash **ONLY** the cover. Remove the frame entirely before washing. Reassemble and install after washing following all instructions included.

CARE INSTRUCTIONS:

Machine wash cold gentle cycle. Do not bleach.
Line dry or tumble dry low. Do not dry clean or iron.

CAUTION:

As with any suction cup, debris, temperature changes, sunshine and excessive use can weaken the holding power. We recommend removing the suction cups at least once per month to clean the window area, clean the suction cups and then re-install them for optimal strength.